

DTXPRO-100U DIGITAL TRANSMITTER

DIGITAL MODULATOR
and TRANSMITTER
REMOTE CONTROL



INTRODUCTION

The DTXPRO-100U transmitter is an integrated transmission system. Included in a 13 RU rack is a modulator, power amplifier, mask filter, and standard accessories. The DTXPRO-100U is tested to FCC specifications.

The modulator used in this assembly is the DXDPRO-MB. The DXDPRO-MB is an all channel modulator with adaptive linear and nonlinear correction controllable via an Ethernet IP connection. Many additional features are included in this basic modulator such as TRANSMITTER REMOTE CONTROL and STATUS MONITORING, GPS RECEIVER, ASI or SMPTE 310M, and FAULT NOTIFICATION VIA EMAIL. This unit will operate with 110 VAC or any 48 VDC TELECOM back up system in case AC Mains fail.

The DR50PRO provides power amplification to achieve the desired power output level to comply with FCC license requirements. LDMOS 50 VOLT DEVICE TECHNOLOGY is used throughout the HPA section for state-of-the-art performance. This unit is wired to operate off 48 VDC or 110 VAC. The 48 VDC is automatically switched on in case the AC MAINS fail. This feature is activated only if a 48 VDC auxiliary power source is available.

An FCC Compliant STRINGENT MASK FILTER is supplied and is built into the rack. Additional components are included to sample forward and reflected power as well as samples for the adaptive linear and nonlinear corrector. The system transmitter is protected using an ISOLATOR between the mask filter and the HPA. Any failures in the filters or antenna will be detected by the onboard protection circuits. This transmitter includes a LOW PASS FILTER for additional harmonic suppression in the GPS Bands.

Pineapple Technology, Inc. warrants the DTXPRO LINE of transmitter products for 2 years from ship date. Extended warranty is available for an additional 5 years. Contact PTI sales for details.



PINEAPPLE TECHNOLOGY, INC.

www.ptibroadcast.com

DTXPRO-100U DIGITAL TRANSMITTER

DIGITAL MODULATOR and TRANSMITTER REMOTE CONTROL

TRANSMITTER GENERAL SPECIFICATIONS

FCC COMPLIANT APPLICABLE SERVICE REQUIREMENTS
 STANDARDS ATSC (8vsb), A/53, ASI
 MODULATION 8 LEVEL VSB TRELLIS ATSC COMPLIANT
 ADAPTIVE CORRECTION . LINEAR & NON LINEAR CORRECTION
 TS OPTIONS ASI OR SMPTE-310M
 CLOCK STABILITY <2ppm (GPS LOCK AVAILABLE)
 CONTROL ETHERNET WITH WEB PAGE GUI
 ACCESS PROTECTION THREE-LEVEL PASSWORD PROTECTION
 KEY PERFORMACE TEST.... SHOULDER LEVELS -62 dB TYPICAL
 MER/SNR -35 dB TYPICAL
 FREQUENCY RANGE *470-810 MHz
 RF OUTPUT POWER 25-100 WATTS
 MASK FILTER 6 POLE STRINGENT FCC MASK

LOW PASS FILTER ADDITIONAL HARMONIC SUPPRESSION
 FOR GPS BAND
 PRIMARY POWER - 110 VAC 50/60 CYCLE
 - 48 VDC (42-50 V RANGE) 20 AMPS
 MINIMUM
 REMOTE CONTROL 12 STATUS AND 12 ALARM OPTIONS
 ASSEMBLED RACK 19 INCH 13 RU RACK
 WIDTH 21 INCHES (534 mm)
 HEIGHT 25 INCHES (635 mm)
 DEPTH 24.5 INCHES (623 mm)
 WEIGHT < 100 LBS (45.4 Kg)

**Frequency range limited by external equipment i.e. filters and isolators. This can be modified and or returned if it becomes necessary to change channels.*

DTXPRO-100U BLOCK DIAGRAM

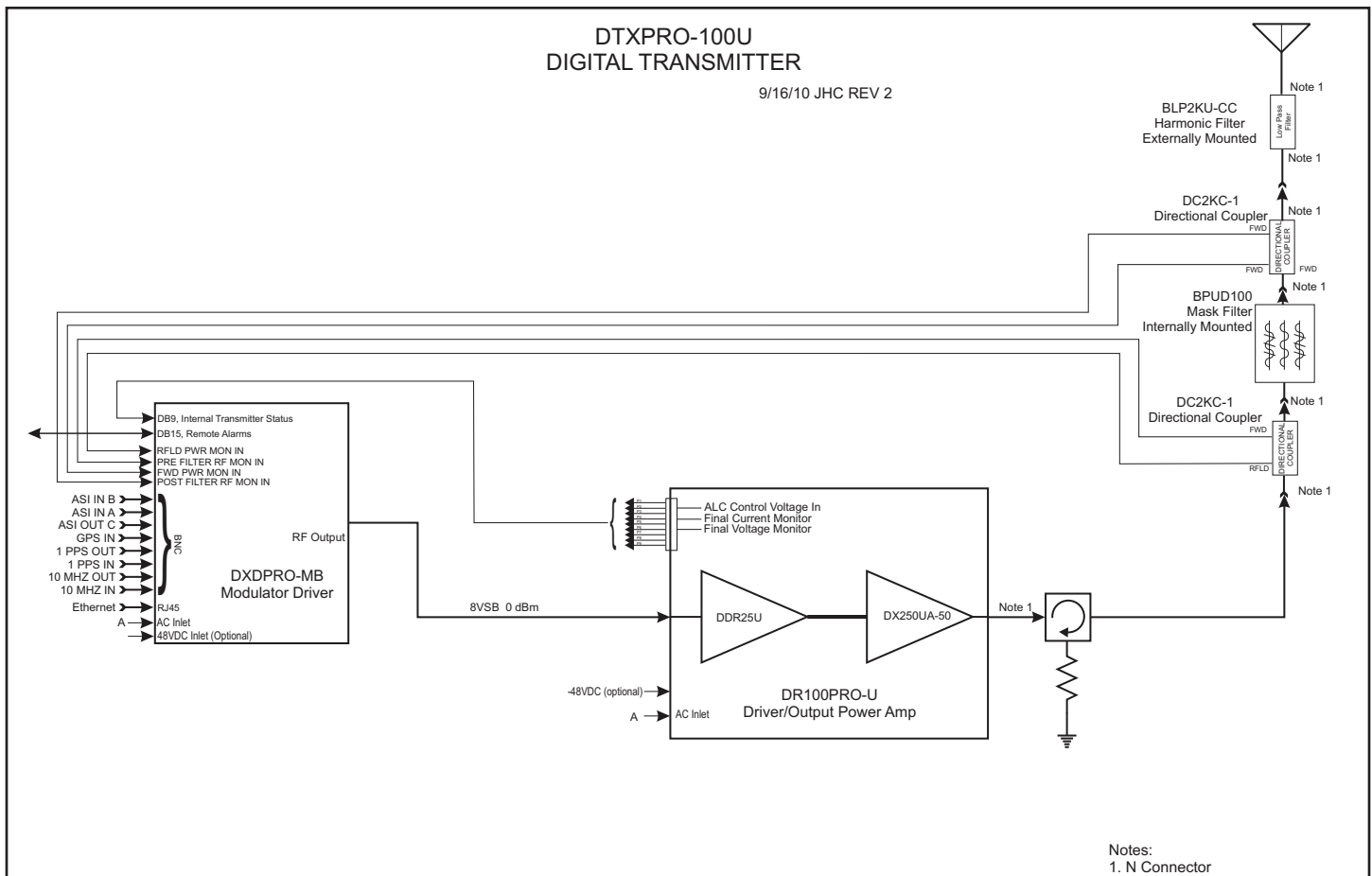

DTXPRO-100U DIGITAL TRANSMITTER

DIGITAL MODULATOR
and TRANSMITTER
REMOTE CONTROL

MODULATOR — FRONT PANEL

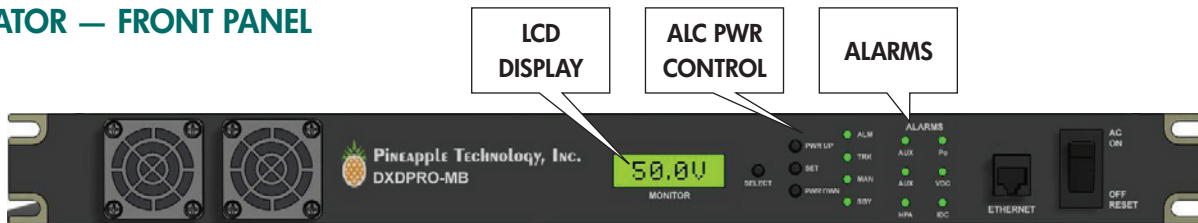

LCD DISPLAY: The LCD DISPLAY provides selected transmitter test data by depressing the SELECT switch located on the right side. Some of the options include the following;

1. RF POWER OUTPUT LEVEL
2. REFLECTED POWER LEVEL
3. DC SUPPLY VOLTAGE
4. DC CURRENT

ALC CONTROL PANEL: The ALC section serves two important functions.

1. Provides a means for raising or lowering transmitter power level.
2. Once the desired power level is reached, the set switch places the ALC circuit in the TRACK MODE. In the TRACK MODE THE OUTPUT LEVEL IS CONSTANT.

ALARM PANEL: The alarm LEDs indicates status of key alarms. Key alarms include the following;

- a. LOW OUTPUT POWER.....NORMAL (GREEN) FAULT (RED)
- b. HIGH REFLECTED POWER.....NORMAL (GREEN) FAULT (RED)
- c. 48 VDC SUPPLYNORMAL (GREEN) FAULT (RED)
- d. AC MAIN POWER*NORMAL (GREEN) FAULT (RED)

*48 VDC backup power required

REAR PANEL

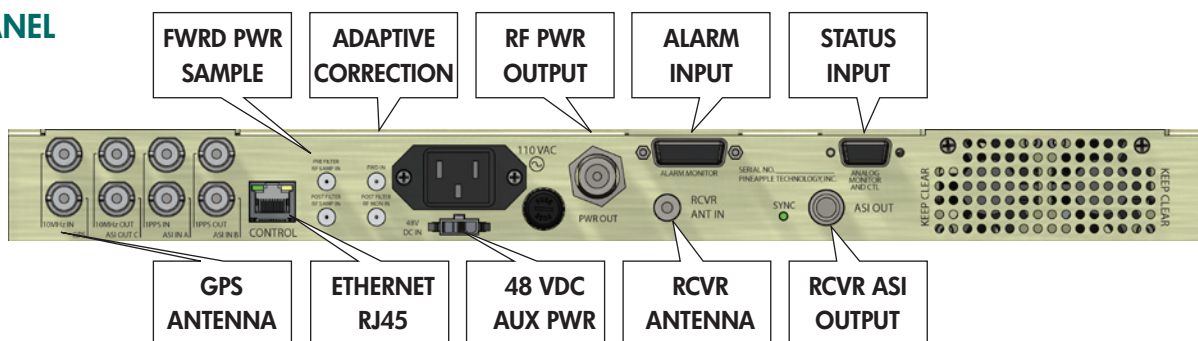

Mating Connectors

BNC JACK 75 OHMSGPS, ASI IN, SMPTE-310
 ETHERNETRJ-45
 RF MONITORINGSMA JACK
 ADAPTIVE SIGNAL.....SMA JACK
 RF OUTPUT.....TYPE N JACK

RECEIVER ANTENNA.....TYPE F JACK
 ALARM INPUTS.....DB 15 JACK
 ANALOG STATUSDB 9 JACK
 48 VDC INPUT.....MOLEX 3P

DTXPRO-100U

DIGITAL TRANSMITTER

DIGITAL MODULATOR
and TRANSMITTER
REMOTE CONTROL

WEB PAGE GUI

Web Page Commands

- Click and drag (XMTR ICON) to lower 1/2 page to see status and alarms
- Click and drag (LINEAR ICON) to lower 1/2 page to control linear correction
- Click and drag (NONLINEAR ICON) to lower 1/2 page to control nonlinear functions
- Click and drag (MUTE ICON) to lower 1/2 of page to mute and un mute xmtr
- Click and drag (RF OUTPUT) to change the output level from modulator
- Click and drag (BELL ICON) to view modulator alarms
- Click and drag (GPS ICON) to setup GPS receiver
- Click and drag (SWITCHING ICON) to select input port for ASI or SMPTE-310

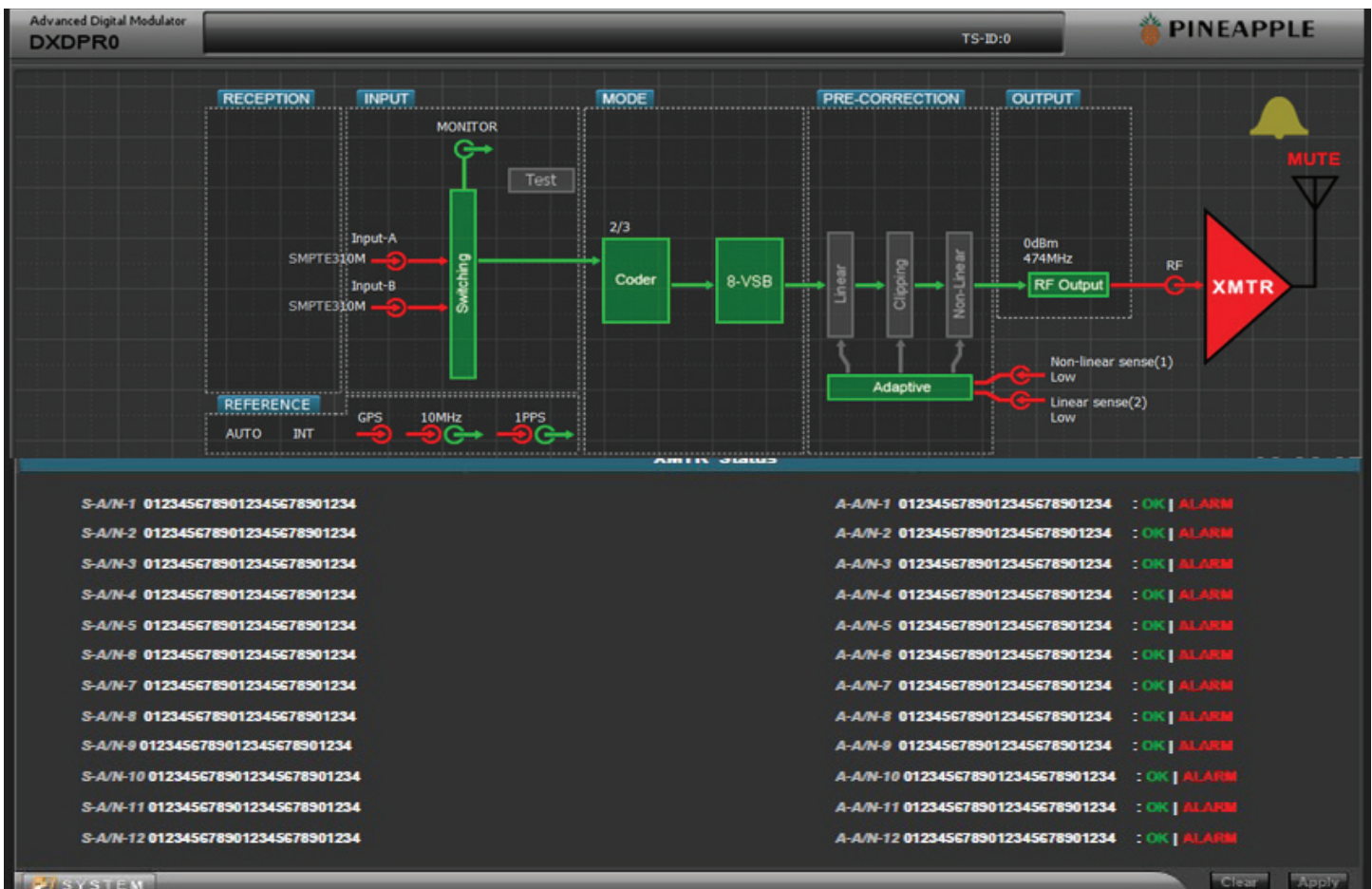

DR100PRO FINAL AMPLIFIER

The final amplifier Mainframe includes the following items

1. UDD25 HIGH GAIN DRIVER WITH ALC CONTROL
2. DX250 LDMOS FINAL AMPLIFIER STAGE
3. 50 VDC POWER SUPPLY

BLOCK DIAGRAM DR100PRO-U

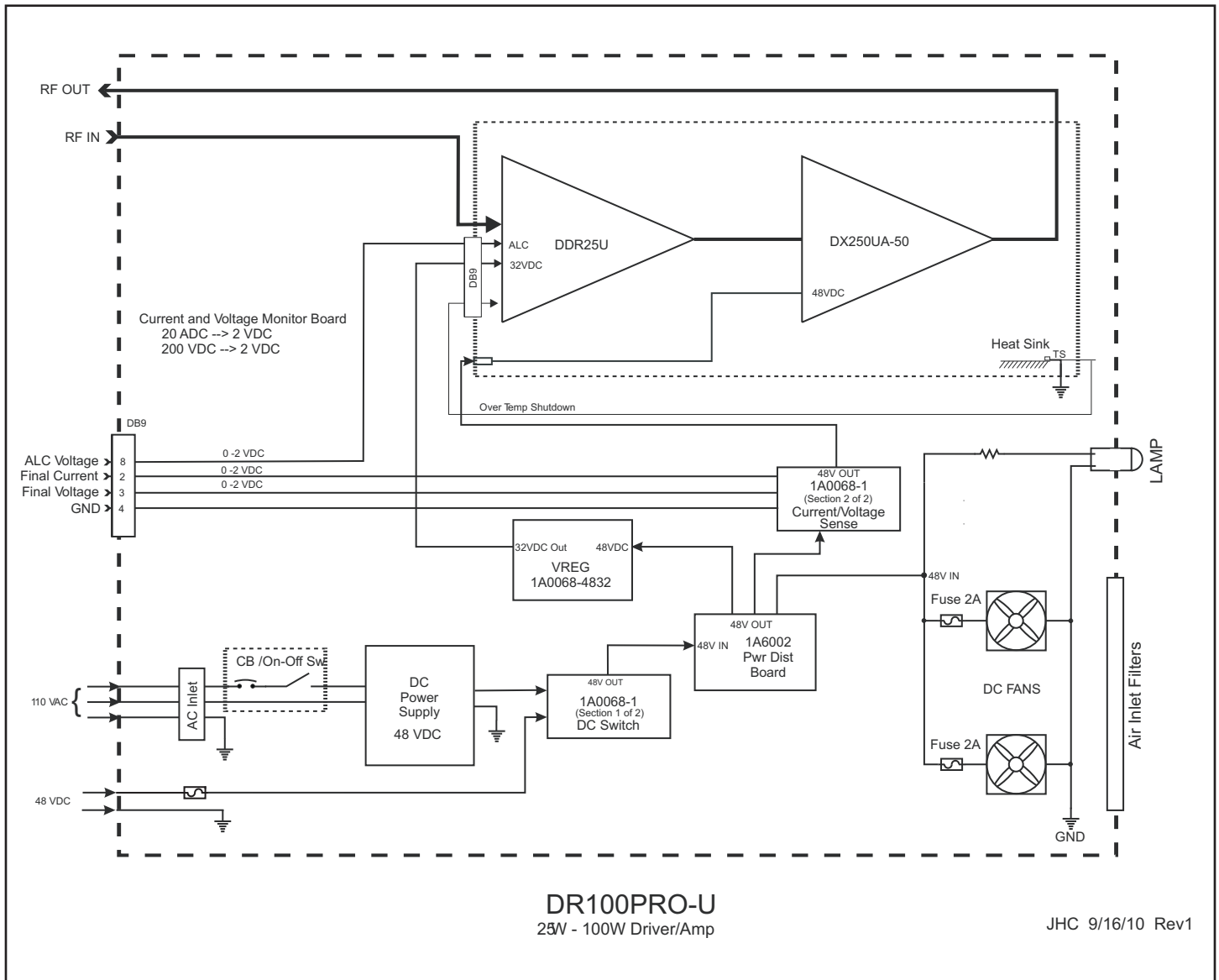

PINEAPPLE TECHNOLOGY, INC.

Web site: www.ptibroadcast.com

4231 Pacific Street, Suite 27, Rocklin, CA 95677

(916) 652-1116 . Fax: (916) 652-1161
U.S. Toll-free (888) 888-8229

ASSEMBLED IN U.S.A. Some products include foreign components.
Information contained herein is subject to change without notice.
© 2010 Pineapple Technology, Inc. All Rights Reserved. Rev. 9/22/2010